

Spring Grove Area School District
Project Triton SLI Rocketry 2016-17
Preliminary Design Review



Project Triton

General Information

1. School Information

Name: Spring Grove Area High School
Mailing Address: Spring Grove Area High School
1490 Roth's Church Road
Spring Grove, PA 17362

Name of Team:

2. Adult Educators:

Rosemary Cugliari

Spring Grove Area High School Principal
Phone number: (717) 225-4731 ext. 7060
Email: Cugliarr@sgasd.org

Brian Hastings

Physics teacher, Rocket Scientist Club Coach
Phone number: (717) 225-4731 ext. 7220
Email: Hastingsb@sgasd.org

Renee Bosak

Biology teacher, Rocket Scientist Club Coach
Phone number: (717) 225-4731 ext. 7242
Email: EatonR@sgasd.org

3. Safety Officer:

Brian Hastings

Level two NAR Representative
Phone number: (717) 225-4731 ext. 7220
NAR 96571 SR

4. We are not part of a USLI team, we are a SL team.

5. Key Managers:

Brian Hastings - Advisor and NAR representatives of students
Renee Bosak - Advisor and Supervisor of students

Mr. Sengia - Instructional Technology Specialist
Sarah Staley - Captain

6. For Launch Assistance, Mentoring, and Reviewing our team will be working with the local NRA representatives along with MDRA (Maryland-Delaware Rocketry Association) for all questions and launches

Table of Contents

General Information

School Information.....	2
Adult Educators.....	2
Safety Officer.....	2
Educators and Mentors Biographies.....	5
Key Managers and Student Participants.....	5-8
Changes Since Proposal.....	8

Facilities and Equipment

Facilities Available.....	9
Computer Equipment.....	10
EIT.....	10
Technical Standards.....	10

Safety

Equipment Safety in Spring Grove Area High School/Safety Plan.....	10-24
NRA/TRA Personal Review.....	24-25
Student Briefings.....	25
Methods for Including Necessary Caution Statement.....	26
Plan for Complying with Laws.....	26-27
Plan for Motor Handling and Storage.....	28
Team Agreements.....	29

Technical Design

Proposed Rocket (A-G).....	30-39
----------------------------	-------

Educational Engagement

Educational Plans.....	40
------------------------	----

Project Plan

Schedule and Timeline.....	41-43
Meetings.....	43
Budget Plan.....	44
Funding Plan.....	45-46
Community Support.....	46
Sustainability of Rocket Project.....	46-47

Team Members

Mrs. Bosak: Biology Teacher and Assistant Coach

I have been a Biology teacher at Spring Grove High School since 2009. Since then, I have coached the Marching Band and Junior High Track and Field and have advised the Gay-Straight Alliance, Science Fair participants, the Envirothon team, and the SLI team. In addition, I have been a member of the York Jaycees, a local community service organization, since 2009. I finished my Master's degree in Classroom Technology in 2013. In my spare time, I enjoy spending time with my friends and family, hiking, biking, reading, and training for 5K races and half-marathons. I am a NAR member and have a level 2 certification.



Brian Hastings: Instructor and Head Coach

I have been a teacher at Spring Grove for 19 years, teaching Physics 1, Physics 1 Honors, and AP Physics 1 and 2. I have an Honors B.A. in secondary education Physics, a masters in science education and 60 graduate credits past my Master's Degree. I have taught graduate courses to teachers and for the past 15 years have taught fast-paced high school physics for Johns Hopkins University's Center for talented youth program. As a Rocket Scientists' coach, I have started a Science Olympiad team, a Vex Robotics Team, Physics Olympics Team, and a Team America Rocketry Challenge Team. The Science Olympiad team has advanced to the state level each of the last ten years. We have been participating in TARC for 9 years and have advanced to Nationals each of the past 6 years, placing fourth overall at Nationals in 2012, and eighth at the Nationals in 2013. I am a NAR member and have a level 1 certification. Currently I am building a rocket for level 2 NAR certification.



Lindsay Mummert 15 Sophomore: Safety Specialist

I joined this club because this year I started to take an interest in science. I'm hoping this club will branch out my options for after college since I've decided to take a different path in life. I'm so honored to be in this club because it makes me feel good about myself since only 10 schools have it. I also feel like this is going to help with communication with others and making decisions. I'm also apart of GSA because I enjoy giving back to others and love helping others who are having a hard time in life.



Adam Winchell 16 Junior Technical Specialist

I've always been really interested in science since I was little. I was in Science Olympiad last year, but since we don't have a team this year, I wanted to find a new club to be part of. I heard of SLI, but wasn't sure what it was, but as soon as I went to the first meeting, I knew I was going to love it. I am going to go to college to be a science teacher, but am hoping to teach in Biology. Even though I have little experience with rockets, I am hoping to learn a lot and I'm really excited for this year of SLI.



Zach Ruth 17 Junior: Technical Design Specialist

I have always been interested in science. I was in Envirothon in 5th and 6th grade. I loved model rockets early on in my teenage years, and that led me to Team America Rocketry Challenge in my sophomore year. I have played violin since 5th grade, and I participate in the school plays and musicals. Last year, I joined International Thespian Society, which is an honorary theater achievement group. I am a member of the Drama Club and vice president of the Game Club. I am excited to become an SL team member this year.



Lacey Roller 16 Sophomore: Project Plan Specialist

I became a member in SL, because I thought it would be fun to branch out and expand my comfort zone. I will give this club my all, and make sure I don't let my team members down. This club is a huge part in my life now, because not all schools have this wonderful opportunity. I hope that this club will teach me how to become a brighter person, and I hope to step out of my comfort zone and show my team members and the other teams what I'm capable of. I'm also a member of GSA, and that is a huge part of my life that I wouldn't give up for anything.



Sarah Staley 16 Sophomore: Payload Specialist

I am a returning member of the 2015-2016 SLI team Darwin and I am very excited for another fun year in this program. Being a member of the Spring Grove SLI team has become a tradition for my family. It started with my sister in 2009-2013, then with my brother in 2013-2016 and now me. I am the historian of my class and a member of Spring Grove's competition cheerleading squad, and I recently went to Germany through a program offered in our school. I like being around a diverse group of people and that are able to collaborate and work towards our team goals. I also hope to expand my knowledge of rocketry and have many successful launches. Fly high rockets!



Emily Edsall 17 Junior: Safety Specialist

This is my second year in Spring Grove's SLI team. I decided to join the team again to further expand my knowledge on the subject. I am also involved in my school TARC and foreign language clubs. For this year's team, I hope I will be able to play a crucial part in our accomplishments.



Melody Buckley 15 Sophomore: Educational Engagement Specialist

Hi I'm melody and I'm 15 years old and in 10th grade. I am in GSA and the manager of the football team. I was interested in SLI because rockets are pretty cool and awesome. NASA is an awesome space program, and I think it would be pretty nifty to work with them. I think it would also be a great to build rockets and launch them.

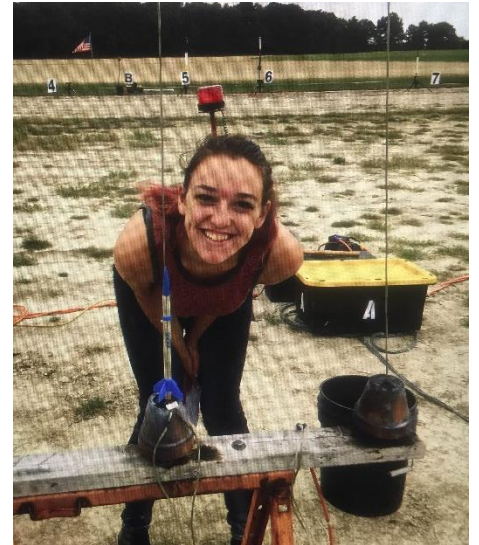

Changes from Proposal

There have not been many changes since the proposal, the team has not had the chance to start the construction side of the project. For now, the plan remains the same. The measurements, scientific experiment, and schedule will remain the same until further notice. The only remote change made was to slightly increase the budget, to act as a safety blanket in case anything would go terribly wrong. Anything else will remain the same, the safety precautions taken and the original plan will remain unchanged.

There was a new team member added Joshua Coson.

Facilities and Equipment

Description of Facilities/Personnel/Equipment/Supplies

- Spring Grove High School:
 - Hours: Monday through Friday 7:25 A.M. until 2:30 P.M. and after school upon instructor availability.
 - Room 135:
 - Gravograph LS100 30W laser
 - Structural Stress Analyzer 100
 - Computers with Microsoft Office and Solidworks
 - Room 130
 - AXYZ Automation INnc 2.2kW 18kRPM TypeB 12-2 CNC Router
 - Compound Dewalt miter saw
 - Framarbandsaw
 - 24” Planer
 - Paasche FABSF-6 spray booth
 - Belt sander
 - Drill press
 - Oliver table saw
 - Orbital sander
 - Room 131
 - Lab Volt 5400 CNC Mill
 - Lab Volt Automation 5500-B0 CNC Lathe
 - EMCO Concept Mill
 - General Model 480 Jointer
 - Jet Benchtop drum sander
 - Victor Metal Lathes
 - Tennsmith sheet metal cutter
 - Miller Spot Welder
 - Baldor Grinder/buffer
 - Room 220
 - Computers with Rocksim 9 and Logger Pro
 - Labquests
 - Drill press
 - Belt sander
 - Reciprocating saw
 - Circular saw
 - Cordless drill
 - Room 222
 - Storage and workspace
 - Room 221
 - Fume hoods
 - Laptop cart with 28 IBM Thinkpads

- Launch site: MDRA Launch field requires an MDRA member for supervision whenever one is free to supervise
- Materials/Supplies
 - There is an abundance of supplies in Room 220
 - All other needed supplies will be ordered at the appropriate time
- Description of Computer Equipment/WebEx required supplies
 - Conference rooms 50 and 51
 - Laptop computers
 - USB web camera
 - Cisco speakerphone
 - School network connection
 - WebEx/connectivity Instructor Contact Information:
 - Instructional Technology Specialist: Mr.Sengia
 - Email: Sengiaj@sgasd.org
 - Phone number: (717)-225-4731 ext.7060

The Spring Grove SLI Team will implement the Architectural and Transportation Barriers Compliance Board Electronic and Information Technology (EIT) Accessibility Standards (36 CFR Part 1194) Subpart B- Technical Standards 1194.21 (a-l), 1194.22 (a-p), and 1194.26 (a-d).http://ecfr.gpoaccess.gov/cgi/t/text/textidx?c=ecfr&tpl=/ecfrbrowse/Title36/36cfr1194_main_02.tpl

Facilities Available to All Students:

In room 220, Mr. Hastings' room, we can work and plan most of our project. It has numerous computers with Logger Pro and Rocksim 9. There is also a drill press, belt sander, and multiple Vernier LabQuests. We have original labquests and have a few new LabQuest 2's. In the room there is also a Craftsman reciprocating saw, a circular saw and cordless drill.

*This room as mentioned above will be our main home for working on the rocket, its construction, and writing of the many papers we must write. Mr. Hastings, as our main mentor, is willing to stay after many late nights to help us work on the project.

Safety

Equipment Safety

Framar Band Saw

Before operating the bandsaw, remove all jewelry, confine long hair, and remove or roll up long sleeves or any article of clothing that could become caught in the blade or the band saw. Also, obtain an instructor's permission to use the machine and ensure that safety glasses are covering your eyes. When cutting, make sure adjustment knobs are tight; the upper blade guard should be around one eighth of an inch above the material being cut. Do not force any material through the blade, attempt to cut a radius smaller than the blade will allow, and do not back out of long cuts. Keep fingers on either side of the cut

line, never on the line. If necessary, use a push stick or scrap block to guide the material through. Do not allow bystanders to stand to the right of the machine, because if the blade breaks, an injury may occur. Never leave the machine until the blade has come to a complete stop. If an injury should occur during the usage of the band saw, stop the machine, step on the brake to stop the blade quickly, inform an instructor of the injury, and then have the rest of the students in the classroom sit outside in the hallway to avoid being in the way of instructors and medical personnel helping the student.

Router

Before operating the router, remove all jewelry, confine long hair, and remove or roll up long sleeves or any article of clothing that could become caught in the router or router bit. Also, obtain an instructor's permission to use the machine and ensure that safety glasses are covering your eyes. Ensure that the power switch is in the off position before plugging in the router. Then, check to make sure that the bit is firmly secured in the chuck and that the piece being worked on is firmly secured. Also make sure that the intended path of the router is free of obstructions. Hold the router with both hands and apply constant pressure. Never force the router or bit into the work. When changing bits or making adjustments turn off the router and unplug it from its power source. If an injury should occur during usage of the router, turn off the machine, inform an instructor of the injury, and then have the rest of the students in the classroom sit outside in the hallway to avoid being in the way of instructors and medical personnel helping the student.

Delta Radial Arm Saw

Before operating the saw, remove all jewelry, confine long hair, and remove or roll up long sleeves or any article of clothing that could become caught in the blade. Also, obtain an instructor's permission to use the radial arm saw and ensure that your eyes are covered by safety glasses. Make all needed adjustments, such as adjusting the blade guard and kickback fingers, while the power is off. Test to see if leaf guards are working properly and that the blade does not extend past the edge of the table. Always firmly hold materials against the fence and pull the blade completely through the material and return blade behind the

fence before removing the material and starting another cut. If too much of the table is cut away, then the instructor must be notified so that the table can be replaced. Wait for the blade to stop before leaving the machine. If an should injury occur during usage of the saw, turn off the machine, inform an instructor of the injury, and then have the rest of the students in the classroom sit outside in the hallway to avoid being in the way of instructors and medical personnel helping the student.

Planer-Surface Sander

Before operating the sander, remove all jewelry, confine long hair, and remove or roll up long sleeves or any article of clothing that could become caught in the machine. Also, obtain an instructor's permission to use the sander and ensure that safety glasses are covering your eyes. Turn on the sawdust collection system. Check all material for loose knots, nails, staples, or any other loose, foreign objects. Never force a material through the planer; after insertion the machine will automatically feed it through. The operator should wait on the other side of the machine to receive the material. Select a proper machine depth and speed for the material being used. Never attempt to plane more than an eighth of an inch of material in one pass. Do not look into the machine at surface level or try to clean debris while the machine is turned on. Always stand to the side, because the possibility of kickback always exists. If injury occurs during usage of the sander, turn off the machine, inform an instructor of the injury, and then have the rest of the students in the classroom sit outside in the hallway to avoid being in the way of instructors and medical personnel helping the student.

Dewalt Compound Miter Saw

Before operating the saw, remove all jewelry, confine long hair, and remove or roll up long sleeves or any article of clothing that could become caught in the blade. Also, obtain an instructor's permission to use the saw and ensure that safety glasses are covering your eyes. Make all changes to the saw and saw blade while the power is off and the plug is disconnected from its power supply. Hold the material firmly against the fence and the table. Allow the motor to reach its full speed before attempting to cut through the material. Make sure that all guards are functioning properly. If injury occurs during usage of the Miter

Saw, turn off the machine, inform an instructor of the injury, and then have the rest of the students in the classroom sit outside in the hallway to avoid being in the way of instructors and medical personnel helping the student.

Jointer

Before operating the jointer, remove all jewelry, confine long hair, and remove or roll up long sleeves or any article of clothing that may become caught in the blade. Also, obtain an instructor's permission to use the jointer and ensure that safety glasses are covering your eyes. Turn on the sawdust collection system. Make all changes or adjustments to the jointer while the power is off. Use a push stick or scrap block if your hands run the risk of coming within two inches of the blade. Do not attempt to take off more than one eighth of an inch at a time. The minimum length of material that can be cut with the jointer is double the size of the blades. If injury occurs during usage of the jointer, turn off the machine, inform an instructor of the injury, and then have the rest of the students in the classroom sit outside in the hallway to avoid being in the way of instructors and medical personnel helping the student.

Hand Sanders

Before operating the hand sanders, remove all jewelry, confine long hair, and remove or roll up long sleeves or any article of clothing that could become caught in the machine. Also, obtain an instructor's permission to use the hand sanders and ensure that safety glasses are covering your eyes. Replace the sandpaper while the sander is off and unplugged. Only use sand paper that is in good condition and properly installed. Place the material that you intend on sanding on a flat surface and sand slowly over a large area. Wait for the sander to stop oscillating before placing it on a secure resting surface. Never carry any corded tool by the power cord. If injury occurs during usage of the hand sanders, turn off the machine, inform an instructor of the injury, and then have the rest of the students in the classroom sit outside in the hallway to avoid being in the way of instructors and medical personnel helping the student.

17

Electric Drills

Before operating the drill, remove all jewelry, confine long hair, and remove or roll up long sleeves or any article of clothing that could become caught in the bit. Also, obtain instructor permission before using the drills and ensure that safety glasses are covering your eyes. Replace the bit while the power is off, installing the bit properly and making sure the chuck is tightened and the chuck key is taken out. Never drill without first marking the hole with an awl. Ensure the material is clamped securely and drill with even pressure. Never carry any corded tool by the power cord. If injury occurs during usage of the electric drills, turn off the drill, inform an instructor of the injury, and then have the rest of the students in the classroom sit outside in the hallway to avoid being in the way of instructors and medical personnel helping the student.

Powermatic Drill Press

Before operating the drill press, remove all jewelry, confine long hair, and remove or roll up long sleeves or any article of clothing that could become caught in the bit or machine. Also, obtain instructor permission and ensure that safety glasses are covering your eyes. Replace the bit while the power is off, installing the bit properly and making sure the chuck is tightened and the chuck key is taken out. Firmly secure the material that you are drilling with vises or clamps. Adjust the table to avoid drilling into it and pick the correct size bit that is properly sharpened. If the drill becomes stuck turn off the machine and inform an instructor. Select the proper speed for the material. If an injury occurs during usage of the drill press, turn off the machine, inform an instructor of the injury, and then have the rest of the students in the classroom sit outside in the hallway to avoid being in the way of instructors and medical personnel helping the student.

CNC Router

Before operating the router, remove all jewelry, confine long hair, and remove or roll up long sleeves or any article of clothing that could become caught in the bit or machine. Also, obtain an instructor's permission to use the router and ensure that safety glasses are covering your eyes. Turn on the sawdust

collection system. Make all adjustments while machine is off. Materials must be firmly secured before the project is run through the router. A person needs to be with the machine during the entire operation.

Check to make sure that the spindle rotation, speed, and depth of cut are all correct before starting the machine. Only clean the machine while it is off and make sure that all setup tools are cleared from the table. If an injury occurs during usage, turn off the machine, inform an instructor of the injury, and then have the rest of the students in the classroom sit outside in the hallway to avoid being in the way of instructors and medical personnel helping the student.

Oliver Table Saw

Before operating the table saw, remove all jewelry, confine long hair, and remove or roll up long sleeves or any article of clothing that could become caught in blade. Also, obtain an instructor's permission to use the table saw and ensure that safety glasses are covering your eyes. Turn on the sawdust collection system. Make all adjustments to the blade or guide while machine is off. Gullets of the blade must clear the top of the material. Never use the miter gauge and the fence at the same time. The miter gauge is for cross cutting and the fence is for ripping. Use extra caution while using a dado cutting head. Always use a push stick when your hand could come close to the blade and have another person at the other end of the table to catch the material that was just cut. Do not leave the table until the blade stops. If an injury occurs during usage of the table saw, turn off the machine, inform an instructor of the injury, and then have the rest of the students in the classroom sit outside in the hallway to avoid being in the way of instructors and medical personnel helping the student.

Powermatic Belt Sander

Before operating the belt sander, remove all jewelry, confine long hair, and remove or roll up long sleeves or any article of clothing that could become caught in machine. Also, obtain an instructor's permission before using the machine and ensure that safety glasses are covering your eyes. Make all adjustments while the machine is off. Check that there is adequate tension in the belt and that it is not torn before turning on the machine. Keep the material on the table at all times. Keep fingers away from the sand

paper. If an injury occurs during the usage of the sander, turn off the machine, inform an instructor of the injury. The instructor will then have any students in the room go out into the hallway. This will ensure that the students do not interfere with the injured person, instructors, or medical personnel that will be helping the student.

Powermatic Disc Sander

Before operating the disc sander, remove all jewelry, confine long hair, and remove or roll up long sleeves or any article of clothing that could become caught in the machine. Also, obtain an instructor's permission before using the sander and ensure that safety glasses are covering your eyes. Make all adjustments while machine is off. Check that the disc was properly installed and that it is not torn. Keep the material on the table at all times. Keep fingers away from the sand paper. If an injury should occur during usage, turn off the machine, inform an instructor of the injury, and then have the rest of the students in the classroom sit outside in the hallway to avoid being in the way of instructors and medical personnel helping the student.

Powermatic Drum Sander

Before operating the drum sander, remove all jewelry, confine long hair, and remove or roll up long sleeves or any article of clothing that could become caught in the machine. Also, obtain an instructor's permission before using the sander and ensure that safety glasses are covering your eyes. Make all adjustments while machine is off. Use the proper drum for the radius that is being sanded. Keep the material that you are sanding on the table at all times. Keep fingers away from the sand paper. If an injury occurs during usage, turn off the machine, inform an instructor of the injury, and then have the rest of the students in the classroom sit outside in the hallway to avoid being in the way of instructors and medical personnel helping the student.

Craftsman Reciprocating Saw

Before operating the reciprocating saw, remove all jewelry, confine long hair, and remove or roll up long sleeves or any article of clothing that could become caught in the blade. Also, obtain an instructor's

permission before using the saw and ensure that safety glasses are covering your eyes. Make all changes with the power off and the plug disconnected from its power supply. Firmly secure all material to a workbench or table. Allow the motor to reach its full speed before cutting through the material. Hold the saw with both hands while you are using it. If an injury occurs during usage, turn off the machine, inform an instructor of the injury, and then have the rest of the students in the room sit outside in the hallway to avoid being in the way of instructors and medical personnel helping the student.

Craftsman Circular Saw

Before operating the circular saw, remove all jewelry, confine long hair, and remove or roll up long sleeves or any article of clothing that could become caught in the blade. Also, obtain an instructor's permission before using the saw and ensure that safety glasses are covering your eyes. Make all changes with the power off and the plug disconnected from its power supply. Firmly secure all material to a workbench or table. Before cutting, ensure that the cut line is not above the table. At least one person must be holding the material being cut off, as long as that piece is large enough for a person to hold it. Allow the motor to reach its full speed before cutting through the material. Hold the saw with both hands while using it. If an injury occurs during usage, turn off the machine, inform an instructor of the injury, and then have the rest of the students in the classroom sit outside in the hallway to avoid being in the way of instructors and medical personnel helping the student.

CNC Lathe (EMCO Concept Mill 55, Lab Volt 5400 CNC Mill, a Lab volt Automation 5500-

B0)

Before operating the lathe, remove all jewelry, confine long hair, and remove or roll up long sleeves along with any article of clothing that could become caught in the bit. Also, obtain an instructor's permission before using the lathe and ensure that safety glasses are covering your eyes. Make all adjustments while machine is off. The material that you intend on cutting must be firmly secured before the project is run through the lathe. A person needs to be with the machine during the entire operation. Check to make sure that the spindle rotation, speed, and depth of cut are all correct before starting the machine. Only clean the

machine while it is off .If an injury occurs during the usage of the lathe, turn off the machine, inform an instructor of the injury, and then have the rest of the students in the classroom sit outside in the hallway to avoid being in the way of instructors and medical personnel helping the student.

Victor metal lathes

Before operating the lathes, remove all jewelry, confine long hair, and remove or roll up long sleeves or any article of clothing that could become caught in the work. Also, obtain an instructor's permission before using the lathe and ensure that safety glasses are covering your eyes. Make all changes with the power off. Center the material so that it will not spin off-center. Firmly secure all of the material to a machine. Use the proper speed for the task at hand. Use the correct, sharpened tools. If an injury occurs during usage, turn off the machine, inform an instructor of the injury, and then have the rest of the students in the classroom sit outside in the hallway to avoid being in the way of instructors and medical personnel helping the student.

Paasche FABSF-6 spray booth

Before using the spray booth, turn on the ventilation system and wear proper protection. Use the correct spray for the material and do not inhale toxic fumes. If an injury occurs during usage, inform an instructor of the injury, and then have the rest of the students in the classroom sit outside in the hallway to avoid being in the way of instructors and medical personnel helping the student.

Miller Spot Welder

Before operating the welder, put on proper clothing, welding mask, gloves, and apron. Obtain an instructor's permission before using the welder. Do not look at the welding torch unless you are wearing a welding mask. Ensure that the proper solder is being used and that the materials are secured. If an injury occurs during usage, turn off the machine, inform an instructor of the injury, and then have the rest of the students in the classroom sit outside in the hallway to avoid being in the way of instructors and medical personnel helping the student.

Baldor grinder/buffers

Before using the grinder and buffers, put on safety glasses, check that the spark shield is intact, and obtain an instructor's permission to use it. Keep hands away from the spinning wheel. Adjust the tool rest to the proper height and always use it. If an injury occurs during its usage, turn off the machine, inform an instructor of the injury, and then have the rest of the students in the classroom sit outside the hallway to avoid being in the way of instructors and medical personnel helping the student.

Tennsmith Sheet metal cutter

Before operating the sheet metal cutter, remove all jewelry, confine long hair, and remove or roll up long sleeves or any article of clothing that could become caught in the cutter. Also, obtain an instructor's permission before using the cutter and ensure that safety glasses are covering your eyes. Do not attempt to cut any material thicker than what the machine is rated for. Make sure that the material and blade are free from debris. If an injury occurs during usage, inform instructor of the injury, and then have the rest of the students in the classroom sit outside in the hallway to avoid being in the way of instructors and medical personnel helping the student.

Gravograph LS100 30 watt laser/engraver/cutter

Before operating the laser, ensure that the laser is focused, the vent fan is on, and the right speed and power are selected for the material you intended on cutting or engraving. Obtain an instructor's permission before using the laser. Never look directly into the laser. Stay at the laser throughout the entire process. If the machine cuts an area that you didn't want cut or malfunctions, turn off the machine and alert an instructor immediately. If an injury occurs during usage of the laser, turn off the machine, inform an instructor of the injury, and then have the rest of the students in the classroom sit outside in the hallway to avoid being in the way of instructors and medical personnel helping the student.

Safety Plan

Before any work is done on the rocket, a second mandatory safety meeting will take place to re-inform students of the NAR safety code. When handling potentially hazardous materials, students will be required to read the Materials Safety Data Sheet (MSDS) on the hazardous material. This will be done

before they can work with the material. Team members are to handle the material according to the Materials Safety Data Sheet, including, but not limited to, the handling and storage of the material.

The SL rocket will be constructed in the Spring Grove Area High School. Students will have quick access to the following safety materials: Sellstrom SM Z87+FF Safety Goggles, Splash Aprons, Emergency Eye Wash Stations, Emergency Body Wash Stations, Cantflame Fire Blankets, BFPE type ABC Dry Chemical Fire Extinguishers regularly serviced by Dale E. Ness Inc., and Simplex Fire Alarms. In all rooms where rockets will be assembled and prepared, there are fire detection and suppression systems present. There are also sprinklers in all rooms. We also plan on using nitrile gloves and respirators as the MSDS sheets suggest. These will be used for the handling of potentially hazardous materials.

We have appointed a construction safety officer who is required to certify that all materials and building procedures are in conformance with the NAR High Power Rocketry Safety codes. This construction safety officer has also been appointed as our range safety officer. He will also certify that the launch facility, rocket engine components, and environmental conditions are within safety regulation requirements. Our Safety Officer will be Mr. Hastings. Mr. Hastings will be responsible for the safety and handling of the rocket motors. He is also responsible for the safety of all of the Spring Grove SL participants while he is handling a motor. In addition, he will oversee the construction of the project and will ensure that the Safety Plan is being followed throughout the entire project. Mr. Hastings is NAR Level 3 certified. Therefore, he will also be responsible for the ordering and storage of our rocket motors. He will oversee and make sure there is an emphasis on safety during construction, assembly, and launching of the rocket. Our student safety officer is Melody Buckley. She will ensure that all SL members follow all safety rules and guidelines.

We will incorporate safety as an integral part of the design. The rocket will also be safely inspected and checked throughout the construction. The safety officer will emphasize safety throughout the entire construction. In addition to the safety plan, we will be following the NAR High Power Safety Code guidelines as outlined below:

*Probability is rated on a scale of 1 to 10, where 1 represents a low probability that the risk will present a problem and a 10 represents a very high probability that the risk will present a problem. Risks that are rated at ten or close to ten will be dealt with as soon as possible and handled according to the mitigation and/ the best way to handle the problem.

Risks	Probability of Risk *(1-10)	Impact on Project Progress	Mitigations
--------------	------------------------------------	-----------------------------------	--------------------

We may fail to get valuable data from the rocket.	2	We will need to redesign, rebuild, or reload the payload. This would delay the progress of construction.	The team shall ensure that the payload is properly handled and deal with any design flaws.
The rocket parachute does not deploy and rocket returns unsafely to the ground.	3	We lose a rocket and must build another one, losing work time and time to launch.	The team will carefully insert the parachute and make sure there is enough heat shields the ground material to prevent flame up.
Injury could occur while using coping saw.	2	A leave of absence of a team member could occur due to minor or severe injury and possibly delay the rocket-building progress.	The team will be aware of limbs and fingers when using this tool.
Injury could occur during Exacto knife usage.	5	A small injury could occur, possibly delaying the rocket-building progress.	The team will carry the knife in cautious matter, cut away from oneself, and be aware fingers when using this tool.
Accidental combustion of rocket materials	3	In addition, possible injury and a delay of rocket-building progress could occur.	The team will keep 25 feet away from electrical outlets, open flame, and the indoor magazine.

Allergic reactions to chemicals involved in rocket production	2	Minor or severe chemical burns of team members and possible delay of rocket progress could occur.	The team will make all students aware of each other's allergies and stay away from possible allergens.
Electrocution during electrical outlet usage	1	Minor or severe injury could occur.	The team will only use electrical outlets if hands are dry and static free. The team will keep fingers away from prongs.

Adhesion to materials or self	4	Minor injury and very minor delay of rocket progress could occur.	The team will exercise proper caution when handling adhesive material and will not use too much of the material.
Injury during laser engraver usage	2	Possible combustion of rocket materials could lead to reordering of materials and delay progress.	The team will make sure the laser is on the proper power, speed, and focus settings, and ensure that the exhaust fan is on.
Injury during drill press usage	2	Severe injury and delay of progress could occur.	The team will keep clothing, hair, and body parts away from the drill bit and use safety glasses.
Tripping and falling hazards	3	Minor or severe injury, delay of rocket progress could occur.	The team will make sure the walking path is clear and keep clutter off of floor.
Abrasions and bruises caused by belt sander	2	Minor injury and delay of progress.	The team will keep hands and clothing away from the sandpaper.
Burning caused by soldering iron usage	2	Minor injury and delay of progress.	The team will use soldering iron in a proper manner and use safety gear.
Premature ignition of rocket motors	2	Possible minor or severe injury, the need to reorder rocket motors, and delay of rocket progress.	Ensure that only the proper level certified personal handle the rocket motors and installations as well as reloads.
Team estrangement because of lack of cooperation	1	Delay of rocket progress.	The team will talk calmly and will not fight with one another. The team will respect each other and themselves.

Going over-budget	5	Delay of rocket progress due to the need for more time to fundraise	The team will carefully use all materials, order only the parts needed, keep track of materials, and use the budget wisely. The team will be diligent in fundraising endeavors.
Misuse or mishandling of hazardous materials	2	Minor or severe injury, leave of absence for team member affected, and delay of progress	The team will follow all safety code regulations, laws, and instructions.
Unforeseen rocket design complications	4	Delay of rocket design and rocket building progress	The team will design a stable rocket based on the locations of the center of pressure and center of gravity. The team will also have a NAR representative check rocket design.
Unforeseen payload design complications	3	Delay of payload design and production.	The team will design a payload that will be effective for the size body tube that is used and double-check that the components of the payload are properly made.
Complications during transportation of participants and materials to SL or practice launch sites	3	Delay of rocket progress due to rocket repairs or cancellation of practice flights because of extensive damage.	The team will make sure that the launch date is known in advance and that all specifications are planned out well in advance. The team will pack the rocket well and make sure it is secure during transportation.

Accidental partial or complete destruction of building site	2	Damage to work environment, additional expenditures for repairs, possible progress delay.	The team will ensure that safety guidelines from NAR and the MSDS are being followed.
Team communication failure	3	Rocket/payload may be built incorrectly or too many of one part may be made, causing a slight to major delay of progress or loss of material.	Every team member will have access to other members' email addresses and have the ability to talk during the school day.
Shortage of rocket building materials	2	Major delay due to the need to order new material and wait for it to ship.	The team will double-check all materials before ordering and enforce a checklist while parts are being used.

Commitment complications among team members	2	Loss of time or team member if the complication is too great.	The team will make sure all team members make this their first priority and plan accordingly.
Inhalation of dangerous fumes	2	Minor to severe injury, time lost taking student to ER, delay of progress.	The team will wear proper safety gear, exercise proper use of fume hoods, and be aware of surroundings.
Accidental ingestion of rocket materials	1	Minor to severe injury, delay of progress, possible loss of material.	Only experienced students should work with dangerous materials under proper supervision.
Motor ignition delay	3	Launch delay, loss of motor if it does not ignite, minor to severe injury if motor ignites while personnel are approaching rocket.	The team will only use commercially available and Range Safety Officer-approved igniters.
Rocket catches fire on the launch pad	2	Possible loss of rocket, minor to severe injuries if	The team will bring a fire extinguisher suitable for

		fire is not properly extinguished.	the needs of the fire and according to the MSDS of the motors being used.
Cancellation of launch due to poor conditions	4	Delay of testing.	The team will plan multiple days to launch, be flexible in scheduling practice launches, and practice patience.
Motor ignition failure	3	Delay of launch testing and rocket progress.	The team will ensure that commercially available igniters and motors are used and follow the NAR High Power Safety Code, which outlines what to do during motor ignition failure.

Procedures for NAR/TRA Personnel to Perform:

Brian Hastings is our Level III NAR mentor as well as our safety officer. He will be certifying that the rocket motors that we are using are certified and safe for launch. He will also be ensuring that the engine reload kits are certified and safe for us to use. Mr. Hastings will also be overseeing the construction of the rocket to ensure that the rocket will only be constructed out of lightweight materials

such as paper, wood, rubber, plastic, fiberglass, or, if necessary, ductile metal. He will visit occasionally to inform team members about better construction methods and how to build safely.

Mr. Hastings will verify that the rocket engines and engine reload kits are not broken upon delivery. He will also store the engines and reload kits in a locked Type 4 magazine that meets the requirements of NFPA 1127. He will verify that no sources of fire or heat are within 15 feet of the locker and 25 feet of the rocket motors when they are being used. Mr. Hastings will keep an inventory of the engines and reload kits and an adult supervisor will also ensure the completion of the above steps by the safety officer.

Mr. Hastings will be responsible for controlling the inventory of all engines and rocket motor reload kits. When ready for use, he will also update the inventory of the rocket motors and reload kits to ensure that there are no missing supplies. Engines and reload kits that are not used for flight, but have been checked out for use, will be returned to Mr. Hastings and accounted for in the inventory. Engines and reload kits will be documented with the launch location for that particular motor or reload kit, the date and time it was used in a flight, and the number of the flight. Mr. Hastings will also be ensuring that safety equipment for hazardous materials and handling procedures for hazardous materials are being followed based on the Materials Safety Data Sheets for those materials.

Plan for Briefing Students:

Students will be required to participate in an introductory meeting, including reading of the NAR High Power Rocketry Safety Code to all members of the team. Team members shall also be required to attend more meetings covering the safety codes of the NFPA and FFA. During the meetings, NAR High Power Rocketry Safety Code shall be reviewed again. Examples from past experience will be used to put the discussions in perspective. Materials will be shown to all team members and they will be told of the hazards of the materials before they are able to use them.

Meetings will be held prior to launches as well. In these meetings, safety codes will be reviewed, team members will be made aware of the hazardous equipment, and team members will be informed of

how to avoid other accidents. Team members will be informed on what safety equipment to use while using hazardous materials.

Methods for Including Necessary Caution Statements:

In order to ensure that cautionary statements are included in plans, procedures, and other working documents, we plan to post warning signs on the entrances of the room in which the indoor magazine will be placed. Cautionary statements will be placed on the entrance of room 220 to ensure that participants are aware that hazardous materials are being stored in the vicinity as well. To ensure hazardous adhesives and accelerants are handled with care, warnings will be posted on the door of the cabinet where they are stored to notify users of the risks involved with these materials. We plan on posting the Materials Safety Data Sheet for the motors being used outside of the room in which it will be stored for team members to read before entering the room. In the planned documents we also plan to include detailed plans of our safety plan and any other plans to keep everyone safe such as securing the launch site and reading all postings' on machines and launch fields. During construction and assembly of rocket team members will be required to use Personal Protective Equipment. Team members will be required to wear Sellstrom SM Z87+FF Safety Goggles during construction. They will also be informed at safety meetings on how to use emergency eyewash and ABC Dry Chemical Fire Extinguishers. When handling hazardous materials team members will use nitrile gloves.

Plan for Complying with Laws:

In order to comply with federal, state, and local laws regarding unmanned rocket launches and motor handling, the Spring Grove SL team shall launch its rocket so that it stays in a suborbital trajectory. The team shall also launch the rocket so that it does not cross into the territory of a foreign country, and the rocket shall be unmanned. The rocket shall be launched in a manner that does not create a hazard for any persons, property, or other aircraft. The team rocket shall also be subject to any additional operating limitations necessary to ensure that air traffic is not adversely affected, and to ensure that public safety is not jeopardized.

To ensure further compliance with FAA regulations, the team shall also avoid launching the rocket at any altitude where clouds or other obscuring phenomena of more than five-tenths coverage prevail. This shall include not launching the rocket at any altitude where the horizontal visibility is less than five miles and not launching the rocket into any cloud. The rocket shall not be launched between sunset and sunrise without prior authorization from the FAA and will not be launched within 9.26 kilometers of any airport boundary without prior authorization from the FAA. The team shall not launch the rocket in controlled airspace.

The Class 2 rocket shall not be launched unless the team observes that there are appropriate separation distances between the launch site and any person or property that is not associated with the operations. The separation should not be less than one-quarter the maximum expected altitude or 457 meters (1,500 ft.), unless a person of at least eighteen years old is present and is charged with ensuring the safety of the operation, and has final approval from authority for initiating high-power rocket flight and unless reasonable precautions are provided to report and control a fire caused by rocket activities.

The Spring Grove SL team shall give the FAA and ATC facility nearest to the place of intended operation the following information no less than 24 hours before and no more than three days before beginning the operation:

- a) The name and address of the event launch coordinator, whose duties include coordination of the required launch data estimates and coordinating the launch event;
- b) Date and time the activity will begin;
- c) Radius of the affected area on the ground in nautical miles;
- d) Location of the center of the affected area in latitude and longitudinal coordinates;
- e) Highest affected altitude;
- f) Duration of the activity;
- g) Any other pertinent information requested by the ATC facility.

The Spring Grove SL team shall also research state and local laws regarding rocketry in order to ensure compliance with all laws associated with rocketry in the vicinity of the rocket launch site. The

team shall also be in compliance with all rules and regulations regarding rocket launch sites, rocket motor storage, and rocket launch safety described in NFPA 1127.

Plan for Motor Handling and Storage:

Rocket motors will be purchased through our NAR level III certified representative, Brian Hastings. All motors will be stored within a Type 4 magazine and access will be granted solely to our NAR representative. Mr. Hastings will be responsible for the safe transportation and construction of the rocket motor reloads. Any use of the motor will be under his supervision at all times.

Team Agreements: All team members read and signed a copy of the agreement below.

Spring Grove SL Team Agreements:

As a team member:

1. I agree to comply with all applicable local, federal and state laws.
2. I agree to use of airspace laws of Federal Aviation Regulations 14 CFR, Subchapter F, Part 101, and Subpart C.
3. I agree to handle and use low explosives according to the Code of Federal Regulation 27 Part 55: Commerce in Explosives.
4. I also agree to follow all fire safety regulations according to NFPA 1127 “Code for High Power Rocket Motors.”
5. I will follow the NAR High Power Rocketry Safety Code.
6. I agree to read the Material Safety Data Sheet and follow all of its instructions. I will be aware of the hazards that are involved with the materials that we are using in our project. This includes, but is not limited to, the rocket motor.
7. I will use safety equipment in accordance to its safety regulations during the construction of the rocket.
8. I will obey all instructions given by the project manager and supervisors.

9. I agree to work with my team members in a constructive manner in order to make a safe environment for all team members to work together.

10. I am committed to working on this team until the completion of our project.

11. As a team member, I promise to show up to 75 percent or more of all meetings and do my work when I am assigned and do my work to the best of your own ability.

As a team:

A. We agree that there will be range safety inspections for each of our rockets before they are flown.

Upon inspection, we will comply with the determination of the safety inspection.

B. We agree that The Range Safety Officer has the final say on all rocket safety issues. Therefore, The Range Safety Officer has the right to deny the launch of any of our rockets for safety reasons.

C. We agree that if our team that does not comply with the safety requirements we will not be able to launch our rocket.

I agree to the Spring Grove SL Team Agreements above. I understand that any violation of these rules will result in consequences including getting taken off the team.

Name: _____ Signature: _____ Date: _____

Vehicle Criteria

Section 1

Our mission is to efficiently design, build, and launch a rocket to an altitude of 5,280 feet with a scientific payload while improvising as a team with acquired skills

Our launch vehicle is designed to reach an altitude of about 5280 feet, but not exceed this height. The rocket design has three independent sections, which is less than the maximum of four independent sections as stated in the vehicle requirements section of the Statement of Work. The redundant recovery system will be capable of being set up within two hours of the time that the Federal Aviation Administration flight waiver opens. It will be able to remain in its launch ready arrangement on the launch pad for at least one hour without it or any of its on-board components losing their capability to operate. The launch vehicle will be capable of being launched from either an 8 foot long 1 inch rail, or an 8 foot long 1.5 inch rail. The rocket will be able to be launched from a 12 volt DC firing system, which will be supplied by the Range Services Provider. It will not require any external circuitry or specialized equipment from the ground to initiate the launch, other than what will be provided by the range. The rocket will use an ammonium perchlorate composite propellant that is commercially available and has been approved by the National Association of Rocketry, Tripoli Rocketry Association, or the Canadian Association of Rocketry. The rocket and motor combination that we will use will not exceed an impulse of 2,560 Newton-seconds. The mass of the ballast in the final design to be flown in Huntsville will not be more than 10% of the rocket mass without the ballast. A full scale version of our rocket will be launched prior to the Flight Readiness Review in its final configuration. The full-scale version of the rocket will be identical to the design that was made prior to the launch, and is the same design that was approved by our safety officer. This flight should include the testing of the payload within the vehicle, but if not, mass simulators will be placed at the same approximate location of the payload. Either a full-scale motor or a motor that will closely simulate the predicted velocity and acceleration of the full-scale motor will be used during this flight as well. The vehicle at this launch will also be in its completely-ballasted arrangement as that of what will be flown down in Huntsville. This flight's success will also be documented on the flight certification form by a Level 2 or Level 3 flight observer and will also be recorded in the Flight Readiness Review. The components of the rocket launched during the full-scale flight will not be modified unless approved by the NASA Range Safety Officer. Lastly, the rocket will not use forward canards, forward firing motors, motors that eject titanium sponges, hybrid motors, a cluster of motors or multiple stages.

There are several factors needed for mission success. The mission would be considered a success if the rocket reaches an altitude of at least 4500 feet and no higher than 5280 feet, since the team recognizes that there are still uncontrollable sources of error involved with this project. The mission would also be considered a success if the maximum acceleration is reached so that the Non-Newtonian fluid may undergo the most force for proper testing. The rocket must maintain a straight stable

path and the rocket must also be recoverable within a 2500 foot radius of the launch pad for mission success. The mission will also be successful if the payload collects useable data and the launch is conducted safely without catastrophic failures.

Section 2

For our design, we went through a few ideas, narrowing our selection down to the best one possible. In our final design, we chose fiberglass for our body tube material. A possible alternative to a fiberglass body tube is a phenolic body tube. It is cheaper, but less sturdy. Another possible alternative is carbon fiber. The carbon fiber is similar to the fiberglass, and is lighter, but it is much more expensive than fiberglass. There is also fiberglass wrapped phenolic, which is cheaper, but it would still not be as sturdy as fiberglass. For our fin can, we are creating a plastic slide-on fin can that will be 3D printed by TE Connectivity. An alternative would be through the wall fins, which are more secure, but creates less room in the bottom part of the rocket.

Section 3

We did not choose the phenolic or the fiberglass wrapped phenolic because it is not as sturdy as fiberglass. We did not choose the carbon fiber body material because it is too expensive, and the cost would not be efficient for the extra durability and lower mass. We chose fiberglass as our body tube material because it is very sturdy, and affordable.

Section 4

In the front half of the rocket, we have our nose cone, payload, main parachute, and shock cords. In the back half of our rocket, we have our drogue chute, shock cords, motor retainer, and a motor mount, which is made of 2 centering rings and a small body tube. Our fin can rests on the back half of the rocket.

Physics Rocket
 Length: 105.1815 In. , Diameter: 4.0000 In. , Span diameter: 14.8812 In.
 Mass 24.755681 Lb. , Selected stage mass 24.755681 Lb.
 CG: 53.7079 In., CP: 82.9567 In., Margin: 7.31 Overstable
 Engines: [K510-Classic-None,]







Component	Nose Cone	Front Body Tube	Payload	Electronics Bay	Main Parachute	Drogue Parachute	Fin Can
Mass (Oz.)	27.027	30.000	32.000	40.000	13.400	1.600	24.000

Section 5

For our motor we chose a K510 Classic. This motor is small enough to fit into our rocket, but will deliver enough lift to take it to the required altitude. An alternative motor would be a K560W, which would take our rocket slightly below the required altitude, and would make the mass of the rocket slightly higher. Another alternative motor would be the K5600WW, which would take our rocket to below the required altitude, but make our

flight time slightly shorter due to the lower altitude reached. A possible alternative motor would be the K888, which would take our rocket far below the desired altitude. The motor is also very long, and would take up much room in the back body tube. The flight time using this motor would be very short. The last possible alternative is the L666SK, which would take our rocket to the desired altitude, but the motor is takes up too much space in the body tube.

	[K560W-None]	4892.98	555.47	646.70	18.16	9.53	4892.96
	[K600WW-None]	4778.31	580.54	644.04	18.16	16.20	4778.31
	[K888-None]	4489.57	570.05	646.13	16.73	0.94	4489.57
	[L666SK-None]	4967.45	603.54	646.06	18.48	6.17	4967.47

Recovery Subsystem

Section 6

The recovery system is required for a successful mission. The recovery system is composed of one one 72 inch main parachute, one 30 inch drogue parachute, 2 nylon shock cords that are protected by sleeves of kevlar at the ends closest to the electronics bay, 4 U bolts, a 3.9 inch diameter, and a 12 inch long electronics bay. For the parachute, we chose a 72 inch Iris Ultra parachute from FruityChutes. A standard parabolic chute is not as compact as the Iris Ultra, and will take up more space in the body tube, not allowing as much space for the payload. For our drogue chute, we chose an elliptical parachute, also from FruityChutes. An alternative to this would have been a parasheet. A parasheet does not create as much drag, so the rocket will continue to fall at a quicker rate. For our altimeters, we chose a Perfectflite Stratologger. An alternative to this would have been

Section 7

An alternative to the Iris Ultra Chute would be a parabolic chute. The parabolic chute would take up more space in the body tube, leaving less space for the payload. An alternative to the Elliptical drogue chute would be a parasheet. The parasheet would not create enough drag for our rocket, and would not slow it to a safe descent speed.

Section 8

Our rocket's mass is 396.09 ounces, and for a safe decent, the main parachute will be 72 inches. The main parachute will eject at 600 ft. We also have a drogue parachute, which will be 30 inches, and will slow down the back part of the rocket. This parachute ejects at apogee. Both of these parachutes will work together to bring the rocket back down safely.

Section 9

We chose the Iris Ultra chute for our rocket's main parachute because it is compact, yet large enough to slow the rocket to a safe descending velocity. We chose the Elliptical chute for our drogue chute because it is big enough to slow the rocket down to a safe decent. For our altimeters we chose Perfectflite Stratologger because it accurately reads the altitude, and has a very low chance of a failed reading.











Section 10

Redundancy does exist within the recovery system. In the electronics bay, there are two altimeters, two 9Volt batteries, and 2 sets of black powder ejection caps on the outside

of the electronics bay. This is to ensure that if something goes wrong with one of them, be it the altimeter, the battery, or the black powder ejection, there is a backup to prevent a failed mission.

Mission Performance Predictions

Section 11

133		[K510-Classic-None]	4929.04	551.23	646.01	18.53	8.01	4929.02
134		[K510-Classic-None]	4927.56	551.23	646.01	18.52	11.21	4927.55
135		[K510-Classic-None]	4925.26	551.23	646.01	18.52	14.86	4925.27
136		[K510-Classic-None]	4929.86	551.23	646.01	18.53	5.49	4929.84
137		[K510-Classic-None]	4925.56	551.23	646.01	18.52	14.46	4925.55
138		[K510-Classic-None]	4930.54	551.23	646.07	18.53	0.29	4930.56
139		[K510-Classic-None]	4925.23	551.23	646.01	18.52	14.90	4925.24
140		[K510-Classic-None]	4930.54	551.23	646.01	18.53	0.94	4930.55
141		[K510-Classic-None]	4927.76	551.23	646.01	18.52	10.84	4927.75
142		[K510-Classic-None]	4929.49	551.23	646.01	18.53	6.70	4929.49

These are a few of our rocket's simulations on Rocksim.

Data Graph

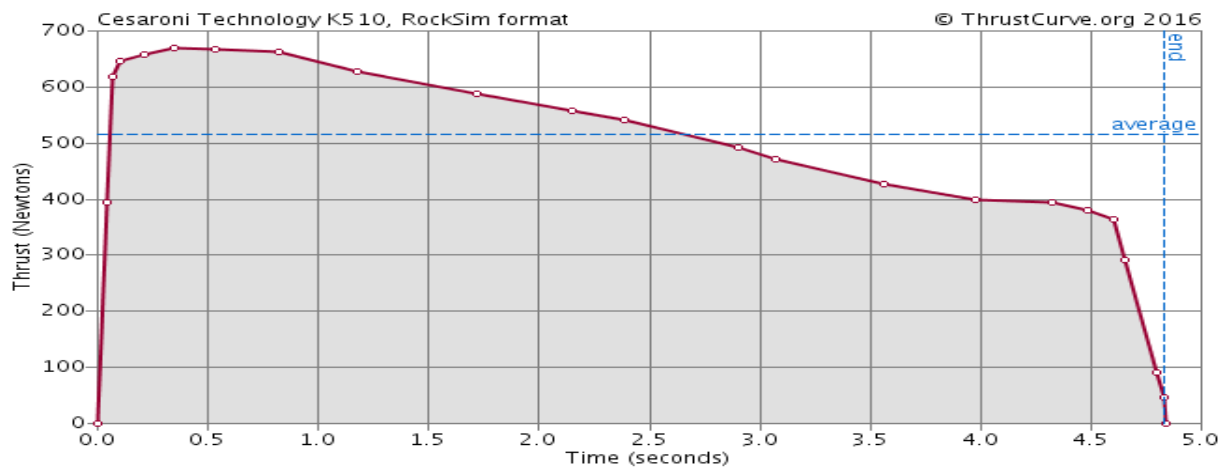

This is a graph showing the motor thrust curve for our motor, a K510 Classic.

Section 12

The stability margin of our rocket is 7.3 overstable. The Center of Pressure is 82.96 inches from the tip of the nose cone. The Center of Gravity is 53.71 inches from the tip of the nose cone.

Section 13

Section	Nose Cone	Front Body Tube	Back Body Tube
Kinetic Energy (ftlbs)	16.73	39.04	30.68

Section 14

Wind speed (mph)	Drift (ft)	Weather Cocking (ft)	Net Drift (ft)
0 mph	0 ft	0 ft	0 ft
5 mph	634 ft	135 ft	499 ft
10mph	1275 ft	272 ft	1003 ft
15 mph	1903 ft	407 ft	1496 ft
20 mph	2534 ft	542 ft	1992 ft

E. Payload Design

How does the material oobleck react to G-force?

Oobleck is a colloid that when pressure is applied to the substance it turns into a solid. When no applied forces are acting on the colloid it turns into a liquid. Are payload is testing if G-forces from the rocket causes the colloid to solidify or remain a liquid. We are going to do this by securing a Solenoid valve to the inside of our rocket and there will be two test tubes on each end. The colloid will be housed in the top test tube and when the rocket goes off the launch pad, a digital timer will open the solenoid valve for a specific amount of time. We expect the colloid to turn into a solid under the influence of G-forces and remain in the top test tube. We will have an altimeter housed in the electronics bay that will connect the circuit, allowing the batteries current to go to a digital timer when the rocket comes off the launch pad. An alternative to just using one altimeter we can use two placed parallel to each other to ensure the solenoid valve indeed opens and closes during launch. The altimeters could also be replaced altogether by using the engines ignition charge to start the timer and or using a thyristor electrical switch. We will do this because if the solenoid valve opens before the rocket is moving we cannot see the accurate results of what happens to colloid under G-forces. Instead of just using one solenoid valve we can house two in the body tube to ensure the experiments successfulness, this however might take up too much room the 4 inch body tube. The timer will power the solenoid for approximately 5 seconds during the ascent of the rocket. We can adjust the timer as needed to match the ascent time of our rocket. This change will be based upon what motor we use. At the end of the ascent the solenoid valve will close trapping colloid in one or more test tubes. If the colloid is still draining when the solenoid valve closes it might not completely close.

An alternative design is to put the colloid into a toy liquid maze tilted at a 20 degree incline too keep the liquid at the top of the maze. It will be held at this angle with a small permanent magnet. When the rocket takes off the launch pad the magnet will be overcome by G-forces. Weights at the bottom of the maze will keep it vertical during ascent. We will capture this via digital moving camera to see the movement of the colloid if any. Problems that could occur with using this design would be the maze would swing to far causing error in our data or the magnet never releases the maze upon

accent. The camera could also malfunction and not capture the experiment. The visual aspect of this design however gives us more exact data of what is happening to the colloid under G-forces, instead making educational assumptions of how the colloid reacted.

The final configuration will include one altimeter, one DC 12 volt battery, two solenoid valves, if room two cameras, a NE555 timer and two test tubes. When the rocket comes off the launch pad, the altimeter will close starting the timer and opening the solenoid valve for how many seconds we adjust it to. The oobleck in the top test tube will either drain to the bottom or stay in the top tube. The solenoid valve will then close when the timer stops and the data will be collected when retrieved. If room cameras in the rocket will add to the data collected in this experiment by visually showing what happens to the colloid when G-forces are applied. Due to the lack of electrical engineering expertise we might also replace to the altimeter and time with a thyristor electrical switch which will eventually do the same thing. Tests will be done to choose the best option.

This is our leading choice in payload designs, because it has less room for err and has two different ways off collecting data. By using the cameras if room and solenoid valves to collect data for this experiment, it gives us a better chance of getting a positive result. With more than one solenoid valve and test tubes we can get more reliable results as well. The timer should be tenths of a second or smaller, because the accent time of the rocket is on the order of 5 to 10 seconds. We can repeat this experiment every time we launch. The two solenoid valves will have a 3D printed connecting value to one tube at the bottom that will collect what drains from both test tubes. The top two test tubes will each be filled less than half full so if the colloid drains the bottom test tube collecting from both can collect all the colloid. This allows for more space for the possibility of cameras being used.

The experiment will be housed in separate compartment, similar to the ebay housing, in the nose cone and extended out to the rockets body. The compartment housing our experiment will be about 14 inches and will be glued to the nose cone. Sheer pins will be used to hold the experiment housing to the body tube and will break during ejection allowing the nose cone to split form the body tube. The parts inside will mounted on one of the fiberglass caps. This cap will have a U-bolt screwed on the outside of the cap, which will be connected with a quick link to the main parachute. A

wooden piece (the sled) will be secured perpendicular to the inner part of the disk/cap allowing the solenoid valves to be removable.

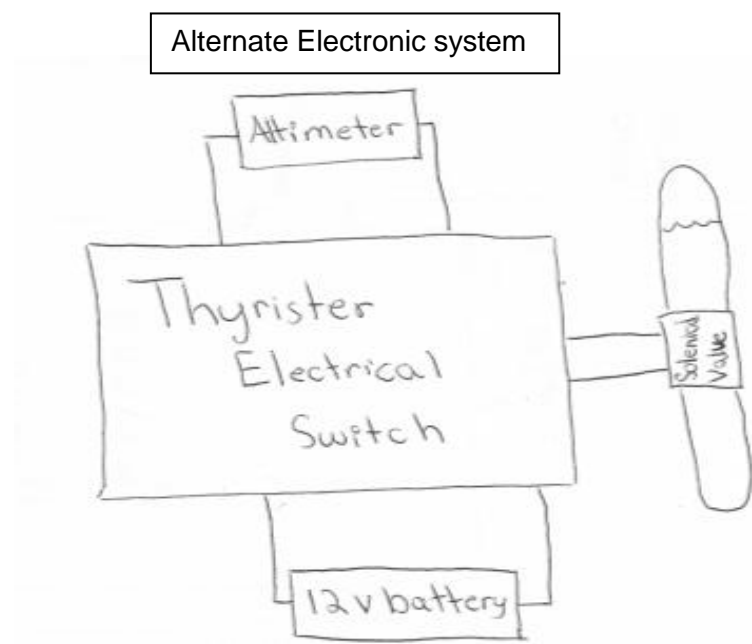
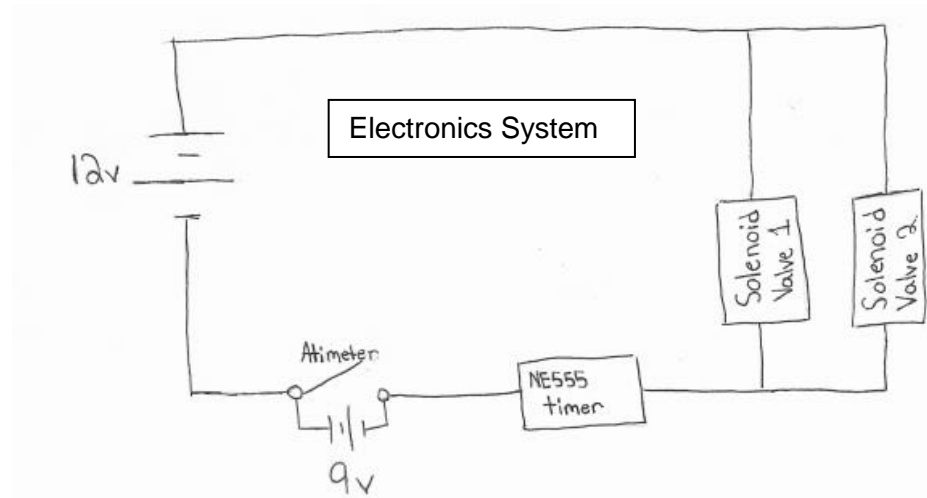
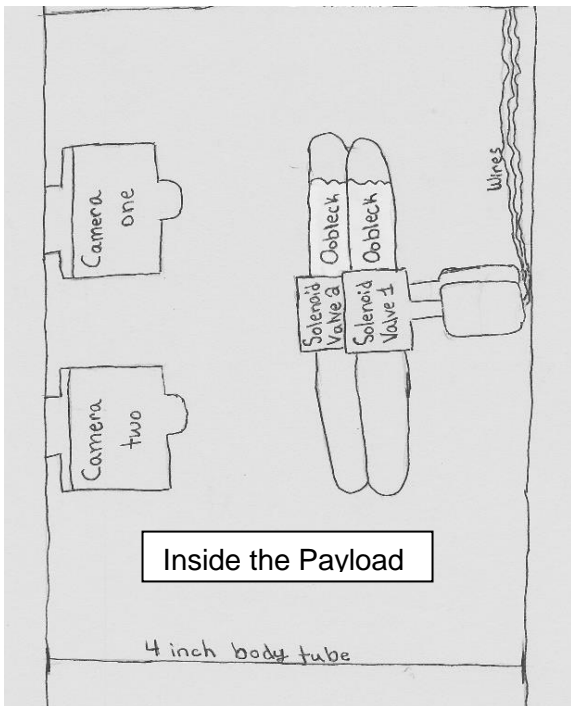

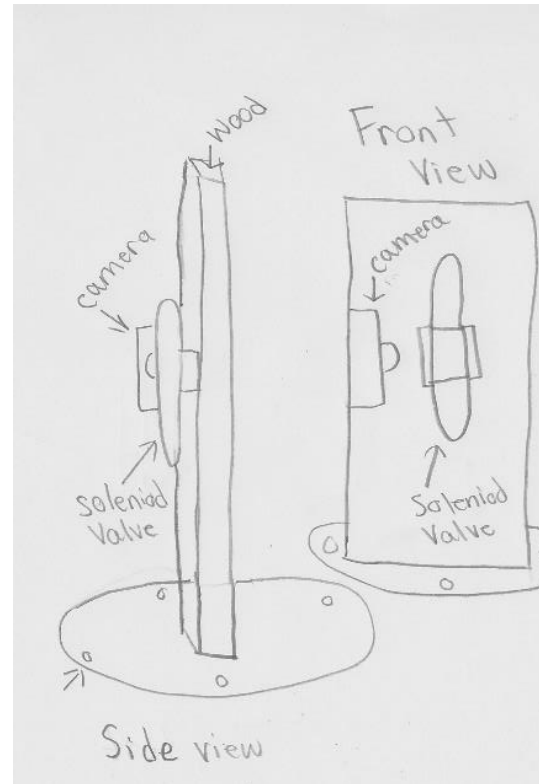
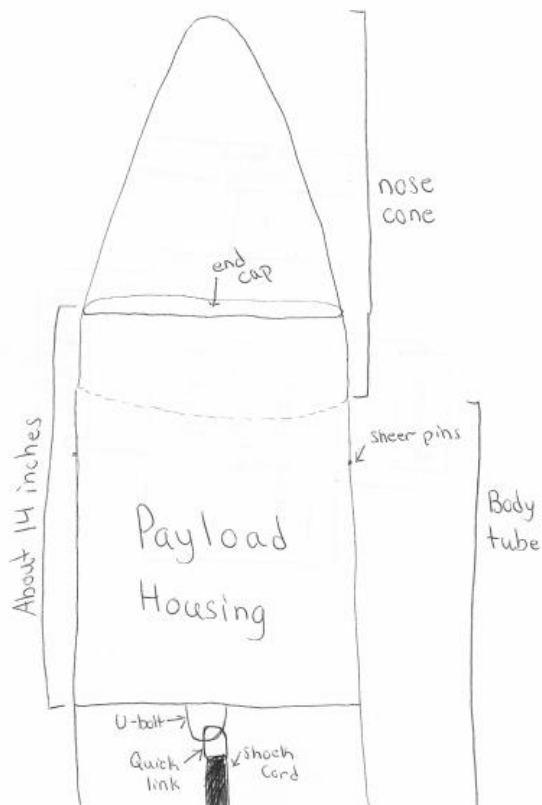

In our rocket recovery system design, will have 2 parachutes connected to shock cord. Each shock cord will have one end connected to the electronics bay. Our shock cord in the bottom half of our rocket will house our drogue parachute which will be connected in the middle of the shock cord. The ends will be connected to the bottom of the electronics bay and the bulkhead on the outside of our payload housed above our motor. Our shock cord in the front half of our rocket will have the main parachute connected in the middle of the shock cord. The ends will be connected to both the top of electronics bay and to the bulkhead on our nosecone with quick links.

Our altimeters in the electronic bay will trigger 2 separate ejection charges with one on each end of our electronics bay. One altimeter will be our main altimeter which will fire an ejection charge at apogee to eject our drogue parachute, as well as fire our ejection charge at 600ft to eject our main parachute. The second altimeter is a redundant altimeter that will fire after 3 seconds to ensure that we have separation of our vehicle parts. The first ejection charge fired from the main altimeter will eject the back half of the rocket off away from the electronic bay. The second ejection charge fired from the main altimeter as well and will eject our nose cone out from the rest of our rocket pulling out the main parachute thus deploying our main parachute

F. Vehicle Requirements

The Spring Grove Area High School Rocket design for the launch vehicle is designed and intended to reach an altitude of 5,280 feet above ground level and not exceed that limit. During the flight, the vehicle is designed and made to remain under mach 1 for the entire flight going up and returning safely back to Earth. This rocket is designed to contain a recovery system and proper components to make the rocket recoverable and reusable. The rocket is also designed to only contain four independent sections all tethered together which is exactly the legal limit. The launch vehicle shall be constructed before reaching a launch site, so that the rocket is capable of being prepared for flight within two hours from the time the FAA flight waiver opens. The rocket is going to contain the proper components needed to keep the rocket in launch-ready configuration for one hour without losing any functionality of any onboard components that are critical to the safety and success of the launch. The launch vehicle shall also contain components which would make it compatible with either an eight foot 1010 or a 1515 rail. The vehicle will also be capable of being launched with a standard 12 volt DC current firing system. It won't need external circuitry or special ground support equipment to initiate its launch. The vehicle will make use of a commercially available solid fuel motor propulsion system which uses an ammonium perchlorate composite propellant approved by the NAR, TRA, and the CAR. The vehicle shall contain no more ballast than 10% of the unballasted vehicle mass. The final rocket design will be flown and recovered in full scale prior to the FRR. The successful flight of the full-scale rocket shall be documented on the flight certification form by a Level 2 or 3 NAR/TRA observer, and then documented in the FRR. After successful completion of the full-scale flight, the rocket and its components will not be altered without the concurrence of the NASA Range Safety Officer (RSO). All of our launch vehicles won't, in any way employ forward canards, forward firing motors, titanium sponges, hybrid motors, or a cluster of motors. The launch vehicle of Spring Grove Area High School has been designed to deploy two separate recovery systems. The first of those two recovery systems is designed to deploy at apogee and consists of a small, drogue parachute. The secondary recovery system, that deploys at a much lower altitude consist of a larger, main chute. This deployment is necessary to reduce the speed of the falling rocket to a safer landing speed. All sections of the vehicle shall have a kinetic energy less than 75 foot pounds of force. The vehicle has also been designed to land within 2500feet of the launch pad, assuming a 15 miles per hour wind, ensuring the safety of those outside of the 2500foot radius of the launch pad. The recovery system circuits have also been designed to be completely separate from the payload's electrical circuits. The recovery system of the rocket has also been designed to include commercially available altimeters. The altimeter contained within the recovery system has also been designed by the manufacture to be armed from the outside of the rocket airframe with an arming switch. The altimeter shall have a power supply reserved for the use of the altimeter only. The arming switch for the altimeter will also be capable of being locked in the ON position for the entire duration of the launch. The arming switch for the altimeter must be less than six feet above the base of the rocket. The main parachute compartment and the drogue parachute compartment shall also contain removable shear pins. During flight a functional electronic transmitting device is

intended to be placed inside the rocket. It will be used to track all of the components of the rocket. The recovery system electronics have also been incorporated into the rocket design in a way that no other onboard electronic devices adversely affect the recovery system. The recovery system will use low-current, commercially available electric matches to ignite all onboard ejection charges. The electronic ignition system for ejection charges won't use a flashbulb. In addition, a rear ejection parachute design will not be used.

G. Technical Challenges and Solutions

Challenge	Solution
Keeping the oobleck mixed.	Mix the two parts cornstarch and one part water to make the the colloid within an hour or less before the rocket is taken out to the payload. This will keep the colloid mixture from separating and losing its properties.
The motor selection will determine the length of the of time the rocket accelerates effecting the time of our experiment	We can use RockSims to get an estimation on the time of our rockets acceleration, so we can then set the timer for our experiment.
Determine the optimum dimeter of our test tubes.	If the test tubes are too big and the colloid might solidify under the G-forces, causing the colloid to drop to the bottom test tube. If the test tube is too small then the colloid might stay in a solidified state casing not change during the rockets accent. We can solve this by trial and err or by placing a small ring in the top test tube so when the solenoid valve opens the colloid either turns into a liquid and flows through the hole, or the colloid stays in the top tube do to a solid state of matter.
Getting all electronics to work together at the same time.	In order to insure that all electronics work together at the same time the electronics will be test prior to flight. We also have two of each electronics (solenoid valve and camera) in the nose cone, if in the event that one of the electronics fails to work we have a back up to collect the data.
Creating a rocket that won't go over 5280 feet.	Design the rocket to fly one mile high or slightly over under perfect conditions. This is accounted for the highly probable that the rocket will weigh 25 percent more than calculated values. Therefore in experimental launches you will have consider all factors like air resistance (that will cause drag) and modify as needed.

Educational Engagement

As a team, we work hard and continuously to get our team down the Alabama each year. We have the support of the Spring Grove Area community, staff, and students to make it possible for us to make this trip an accomplishment. We put our sweat and blood into every last detail of our project. We push ourselves to the limit when it comes time to construct our rocket. We cannot continue this program without the younger students in our district.

In order for our SLI team to be carried on through the years to come, we must begin with educating the children in younger grades so as we graduate, they have the opportunity and knowledge to carry on the program. We need to educate the younger children because without them, we will not be able to carry a rocket down to Huntsville, Alabama in the following years. We are hoping to encourage the younger students of Spring Grove Middle, Intermediate, and Elementary schools to join SLI in high school through presentations and workshops that show just how fantastic and fun SLI is. These presentations will detail what SLI means and what responsibility comes with such an active program..

The current students in the SLI program will run the presentations and programs, which will not only show the younger students that anybody of any intellectual level can join our club, but also to give the SLI members a chance to share their experiences with the younger students. The SLI members will also have the opportunity to show the younger generations what SLI has done for them. SLI is not merely slapping together a rocket and throwing it into the air; it is about teamwork, hard work, and perseverance. SLI gives the students a chance to make friends and surround themselves with a community of people who will help them to succeed.

SLI is working harder this year more than ever to get our younger students involved. We rely on them to carry us into the future of rocketry and the NASA based program.

Project Plan:

1. Timeline

September 2016:

- September 17th: We will be going down to Centreville, MD for a launch to introduce our new team members on how we do our launches.
- September 30th: We will be going down to Greenbelt MD, to tour the NASA Goddard to show what NASA is doing with the rockets.
- Begin fundraising - we will be selling:
 - Cotton candy at home football games
 - 3D printed “rocktopi”

October 2016:

- We will work collaboratively on the Preliminary Design Review.
- We will begin building our sub-scale rocket.
- October 16th - We will launch rocket in Centreville, MD
- October 25th - We will be touring Te Connectivity since they donated a lot of money to our team
- Continue fundraising - we will be selling:
 - Cotton candy at home football games.
 - 3D printed “rocktopi”
 - Paint night

November 2016:

- November 19 & 20th - We will launch our sub-scale rocket in Centreville, MD
- Continue fundraising - we will be selling:
 - 3D printed “rocktopi”
 - Nuts About Granola
 - Yankee Candles
 - Bonus Books
- PDR presentation

December 2016:

- Working collaboratory on our Critical Design Review.
- Continue fundraising - we will be selling:
 - 3D printed “rocktopi”
 - Nuts About Granola
 - Yankee Candles
 - Bonus Books

January 2017:

- Full scale launch
- Continue fundraising - we will be selling:
 - 3D printed “rocktopi”
 - Nuts About Granola

- Working collaboratory on our Critical Design Review.
- CDR presentation

February 2017:

- Full scale launch
- Continue fundraising - we will be selling:
 - 3D printed “rocktopi”
 - Nuts About Granola

March 2017:

- Full scale launch
- Continue fundraising - we will be selling:
 - 3D printed “rocktopi”
 - Nuts About Granola
 - Paint Night event
- Working on our Flight Readiness Review
- FRR presentation

April 2017:

- Travel to Huntsville, Alabama
- Work on Post Launch Assessment Review

Team Schedule:

As far as get-together’s go, there are two types: meetings and sessions. The meetings will be discussions conducted by the Team Captain with the entire, including supervision and comments from them. Sessions will only be for team members to allow them to work without advisor help as a team, though an advisor will supervise them. The schedule will include general and formal meetings, briefing, group sessions, bonding sessions, work sessions, and construction sessions. The dates for these are variable to help better accommodate everyone.

Meetings:

At general meetings, tasks will be assigned and the information of when they need to be completed and turned in. These meetings will be informal and quite short, they will be held prior to the work that is going to be done that day.

The more formal meetings will have a considerable and strict agenda to discuss everything that needs to be done. This will include the progress on certain tasks or problems that have come up throughout the course of the week. Team members and advisors can share their thoughts and discuss them as a team. Team members and advisors can also ask any general questions about the project and/or concerns and can discuss them during these more formal meetings.

Briefings will be informative meetings consisting of a collective report of all work that has been completed and progress on any unfinished tasks. These will be used to inform the team of any changes to the project’s budget, schedule, fundraising, and other changes rather than focusing on what needs to be done.

Sessions:

Sessions will be somewhat of a counseling type of meeting. These will be used to address personal problems and challenges that have come up during the completion of the project. Team members may share personal problems that are outside of the project that are affecting their ability to work well, or explain problems that are preventing them from attending meetings. Other team members can then help in completing their part of the project. Since these are only held with team members, they can discuss how they feel about something else another team member has done, or if something another has done that has upset them in some way in order to best resolve the issue at hand. The sessions will allow the team members to get help in solving personal affairs and dealing with problems within or outside of the project to relieve as much stress as possible. These will help the team understand what is going on with other team members and grow together and help each other. The sessions will be more serious than the others, and are largely going to influence the project as we need everyone to be working at their best cooperatively. Not having this will make the project more stressful not only for those directly having problems, but for the entire team as well.

Part of our effort to make our team grow together and cooperate well, special bonding sessions will be held to improve the bond between team members and advisors. These are designated to help build relationships outside of the project. We will do various activities such as watching movies about science in general as well as more specifically aerospace, and other group favorite movies that we can watch together. As stated earlier, we need to have an open and friendly environment and atmosphere within our teams and these sessions and/or activities are crucial to that kind of team development and maintaining a pleasurable experience for all involved.

Work sessions will be used for working on any and all of the reports needed throughout the project. This will present the opportunity for team members to ask others questions about their part and allows for clarification if need be. This will also be used as a progress check to see what needs to be done and see what has been completed. It will give the chance for the two teams to work together and assist as needed within the time being.

Construction sessions will be used later in the project to actually build the tangible rocket itself. Team members will be paired to work on building specific parts of the rocket or payload. This prevents mistakes and accidents from happening and builds progress within itself. The partners are in case an accident does happen, so that the other partner will be there ready to help if needed. Construction will have adult supervision, so partners can inform them immediately if something requires attention or assistance. Both team members must read and abide by all safety rules regarding the operation of tools, for both their safety and their partner's.

Meeting Times, Session Times, and Proposed Schedule:

_____ Meetings and sessions will be held on several different dates; general meetings will be held every day when the team is capable of meeting together, typically before work sessions and before/after school hours. Formal meetings will be mandatory meetings that will be ideally held once a week from about 3:00pm to 5:00pm. Work sessions will be held during any of the available times after school, allowing for convenience for each team member. Construction sessions, once that point in the project has been reached, will be held once or twice a week. Extra days will be assigned as needed later on in the project to assure that we stay on schedule. These construction sessions will also be under close supervision by an adult so in case any of the aforementioned issues arise.

2. Budget:

<i>Item:</i>	<i>Cost (In Dollars):</i>
Travel to Huntsville	6000.00
Food for All Trips:	2354.00
Practice Trips to Maryland	840.00
Lodging in Huntsville	3600.00
Nose Cone(full scale)	138.00
Nose Cone(sub scale)	118.00
Body Tubes(full scale)	336.00
Body Tubes(sub scale)	157.50
E-Bay(full scale)	70.00
E-Bay(sub scale)	74.00
Rocket Mount	4.99
Fast-Hardener	43.94
Resin	84.96
Shock Cords(full scale)	85.00
Shock Cords(sub scale)	208.00
Large Parachute(full scale)	530.00
Large Parachute(sub scale)	178.00
Small Parachute(full scale)	132.00
Small Parachute(sub scale)	120.00
Centering Rings	55.88
Bulkheads	70.54

Motor Casing	149.95
Reload	531.80
Reload	265.90
Couplers(full scale)	52.00
Couplers(sub scale)	20.00
Motor Mount Tube	9.95
Engine Retainers	72.76
U-Bolts	15.84
Quick-Links	14.88
Altimeters	1119.03
Batteries for E-BAY	25.46
Materials for Fins	70.38
Wires	30.78
All-Threads	6.40
Key-Switches	106.68
Subscale Rocket	500.00
3D Printer Filament	21.22
Camera	99.99
Battery Holder	5.60
Solenoid Valve	9.37
Delay Timer	7.89
<i>Total:</i>	<i>18,336.68</i>

3. Funding Plan:

In order to receive the necessary funds in order to successfully complete this project our team intends to cover the costs through a combination of fundraisers, donations and sponsors/grants all of which will be completed and then sent to our financial advisor for approval. Our club will be taking part in fundraisers throughout the year to help finance our endeavor. Current fundraisers

that will be taking part includes “Nuts About Granola” (information is located at www.nutsaboutgranola.com), selling cotton candy at local sporting events, Bonus Books (information is located at www.bonusbook.com), we now Currently we have already received our grant from TE Connectivity for \$7,500, we also received a grant from Pennsylvania Space Grant Consortium \$2,500, and National Association of rocketry(NAR) Cannon Award \$500 for establishing rocketry course. There are also several previous sponsors who may be interested in. Our clubs are currently accepting all donations and bring donation jars to all the events that we are planning to take part in.

4. Community Support:

To publicize our project, our team will be contacting local television stations like FOX43 of the FOX Corporation and WGAL 8 in the Susquehanna Valley like we have done in previous years as well as contacting local radio stations like 107.7 and 105.7. Lastly we will contact local newspapers to spread the word of the Spring Grove Rockets. We will be sending each of these kinds of organizations information about us and asking if they were willing to spread awareness about our club. We will also be using our own SL website to notify the public about the project and to post updates. We plan on making presentations to both our middle school and intermediate school about our project and the clubs offered at our high school to help get the kids more into and aware of the great possibilities that SLI provides. We also intend to create posters to put around our school and local businesses to promote and encourage sponsorship and donations.

5. Sustainability Plan:

We intend to keep our SL club together now and into the future through a combination of many plans and elements. We intend to maintain all of our current relationships by send them regular reports, maintain an active dialogue with them and taking their feedback into account. Our current relationships are with several certified NAR members, Advanced Application Design and the Engineering Society of York. Now in keeping a steady stream of new members coming into the club we will primarily recruit new members from our TARC teams who have had past experience in rocketry but we are willing to accept anyone who wants to join and is willing to put in the work. We will be using a combination of announcements, posters, and our website to get the word to potential club members. We intend to engage the students of Spring Grove Area School District in our club and mission through a series of assemblies and workshops. Lastly we intend to keep a steady stream of funding coming in through fundraisers, donations and sponsors/ grants. This will all ensure that our club is maintained well into the future. We also plan to:

- A. Avoid safety hazards is to have team members and supervisors read the all operation manuals for the tools and products that will be handled during the completion of our project before proceeding with any of such devices or products, while following the enclosed safety plan.
- B. Address if a team member is comfortable with using a tool at any time or not. · Raise enough funds for our project we will be holding public outreach programs for funding and support we will be contacting local businesses for grants such as our local power company’s (MetEd’s)
- C. Stay on budget, we will keep track of all funds being used and track whether the prices of materials are within the projected coast by researching for the best pricing of the materials. If

going over budget is inevitable, due to rising prices of materials, we will raise more funds from companies using our progress on the project to incite sponsorship from more companies and businesses.

D. In order to make it to Huntsville, we want to work with people, local businesses, and corporate sponsors in and around the Spring Grove area. We plan on spreading awareness of our rocketry programs at Spring Grove to every adult and student in the area, to accomplish this we would like to create hands-on learning experiences for kids in our community to explore and learn more about the rocketry field.

E. We will also be holding public outreach and funding programs at school and local events to help with awareness of our project to get the attention of adults of our community.

F. We hope to have small groups work together and build small scale rockets, each group will have an SL member directing the group to help teach the students to build the small rocket. If feasible, we may launch the said rockets (if they are deemed safe to fly). We want to provide fun hands-on experience for our students so more students will be interested in joining TARC and potentially even SL in the future.

G. In order to spread public awareness, we are planning to contact television stations, such as FOX and our local news channels, to see if they are interested in making a short segment on the SL program of Spring Grove High School. We will also contact local radio stations such as 107.7 and 105.7 to see if they are interested in speaking on behalf of our program here at Spring Grove.